

# HEARING AID

■ T.K. HAREENDRAN

This low-cost, general-purpose electronic hearing aid works off 3V DC (2x1.5V battery).

In this circuit, transistor T1 and associated components form the audio signal preamplifier for the acoustic signals picked up by the condenser microphone and converted into corresponding electrical signals. Resistor R5 and capacitor C3 decouple the power supply of the preamplifier stage.

Resistor R1 biases the internal circuit of the low-voltage condenser microphone for proper working. The audio output from the preamplifier stage is fed to the input of the medium-power amplifier circuit via capacitor C2 and volume control VR1.

The medium-power amplifier section is wired around popular audio amplifier IC TDA2822M (not TDA2822). This IC, specially designed for portable low-power applications, is readily available in 8-pin mini

DIP package. Here the IC is wired in bridge configuration to drive the 32-ohm general-purpose monophonic earphone. Red LED (LED1) indicates the power status. Resistor R8 limits the operating current of LED1.

The audio output of this circuit is 10 to 15 mW and the quiescent current drain is below 1 mA. The circuit can be easily assembled on a veroboard. For easy as-

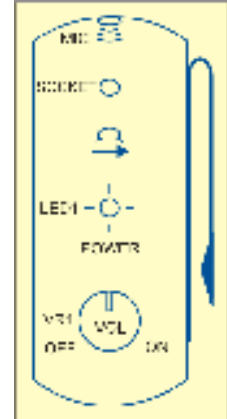

Fig. 2: Enclosure

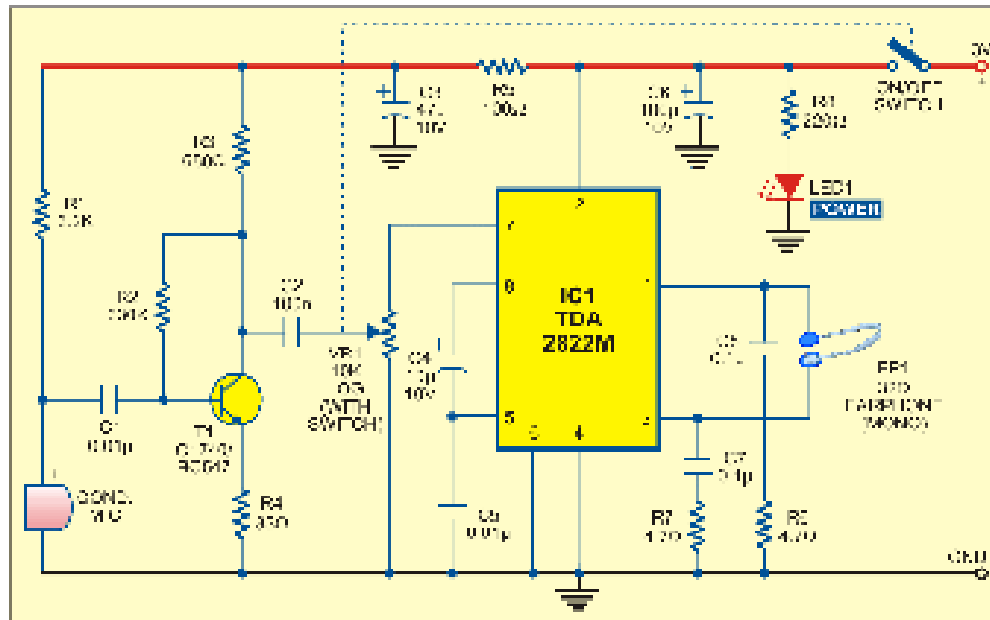

Fig. 1: Hearing aid circuit

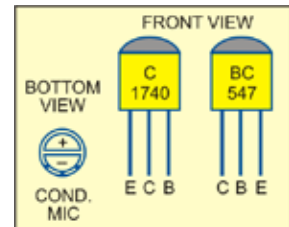

Fig. 3: Pin descriptions of cond. mic, C1740 and BC547

sembling and maintenance, use an 8-pin DIP IC socket for TDA2822M. Proposed enclosure (with earphone socket) for the assembled unit is shown in Fig. 2.

**Note.** The complete kit is available at Kits'n'Spares. ●